

Nidus is launching its first furniture collection. Often, but not always unique pieces or ready-mades, all objects arise from Nidus' own architectural projects. Each piece continues to carry on the story of a building, filling other spaces with the life and soul of another physical place.

[The Story](#)

[Objects](#)

[Floor Lamp](#)

[Carpet](#)

[Sofa](#)

[Armchair](#)

[Table Lamp](#)

[Wall Console](#)

[Quilt](#)

[Pen](#)

[Console](#)

[Table](#)

[Overview](#)

[Building Culture](#)

[Imprint](#)

# The Story

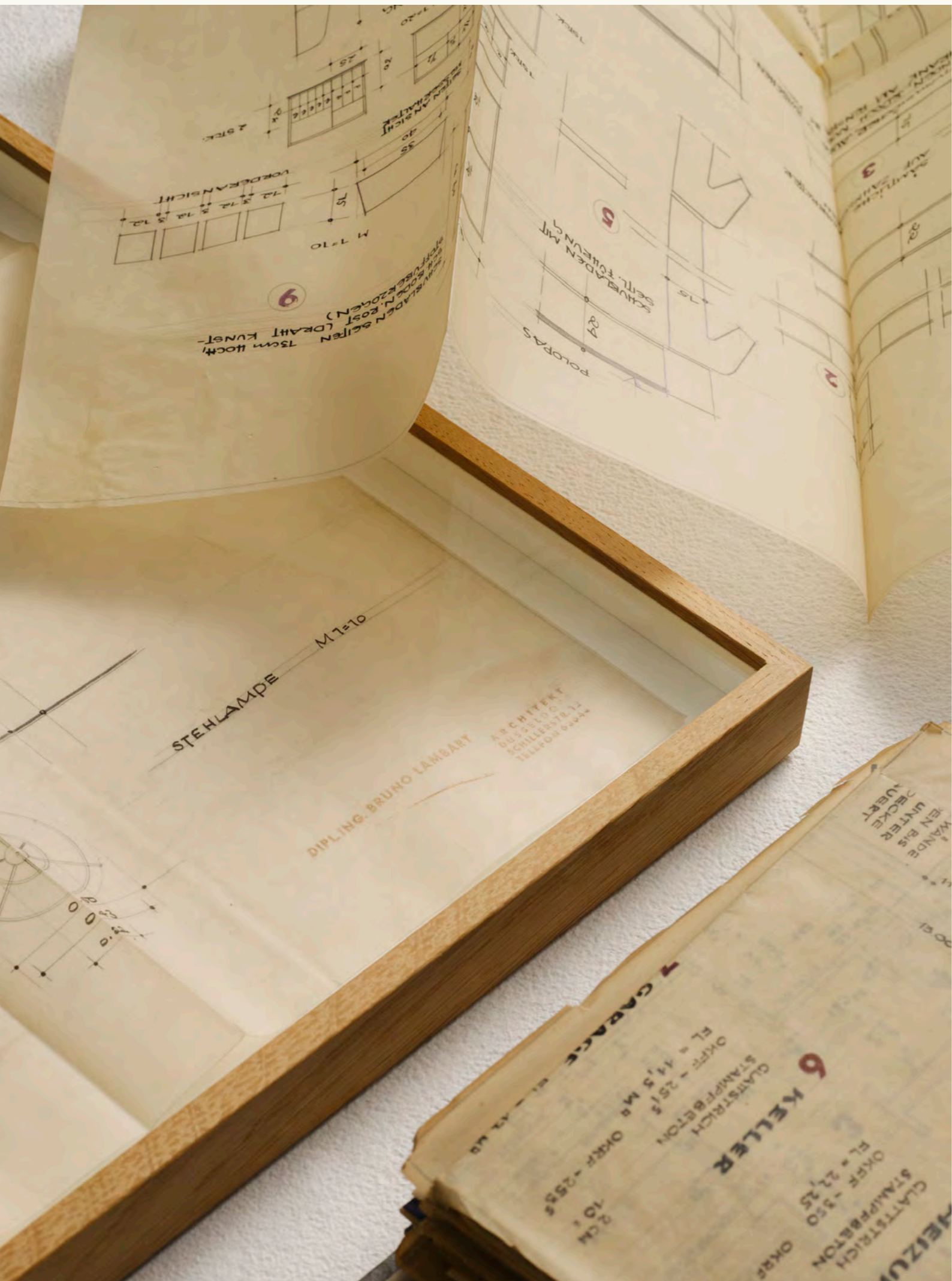

1

Everything started with a Leitz folder. For the handover of House Bruno Lambert we were expecting protocols, old rental agreements, perhaps a few static calculations from the 1950s.

Instead, we were being given the most careful ink drawings, from the facade to the holder for Bruno Lambert's drawing scroll. Overwhelmed by Bruno's love for every detail in his house, we also wanted to continue to tell the stories of our houses beyond the architecture, almost like a miniature that retains the place and captures its essence.

Of course, the first piece of the collection is derived from House Bruno Lambert - a floor lamp that was immortalised in the legendary photograph of the establishment of his office down below. Just as this first piece, all other pieces of the collection too, originate from one of our architectural projects. Take for example our table lamp, made from drill cores from the former fittings factory, which was subsequently turned into our office space. Sankt Göres' special floor plan of a duplex house is now manifested in our first carpet, the uncompromised and distinct setup and cycle-oriented construction of our Kreuzberghof inspired our sofa collection as well as our quilted plaid.



2

From now on the Nidus furniture collection will continue to grow project by project.

- 1 House Bruno Lambert, condition around 1955
- 2 Bruno Lambert and his colleagues in his house with the floor lamp on the right side

3

# Floor Lamp

The first piece and start to our collection. Originally designed by Bruno Lambart for his studio and immortalised in his legendary photograph of the office formation, we rediscovered this exceptional floor lamp and brought it back to the here and now. Starting off with an exact replica of the original base frame made from coated steel, we refined the lamp shade with a classic Dior fold and a pure linen fabric. This floor lamp is the perfect example of dateless beauty coming from a fifties design and not forfeiting any of its allure.

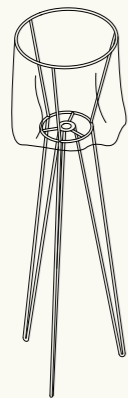

Dimensions: ca. 45 x 165 cm

Design: Bruno Lambart x Nidus, 1955 / 2023

Handcrafted in Düsseldorf, Germany

Lamp shade: 100% natural linen, undyed

Base frame: Coated black steel

Project: House Bruno Lambart



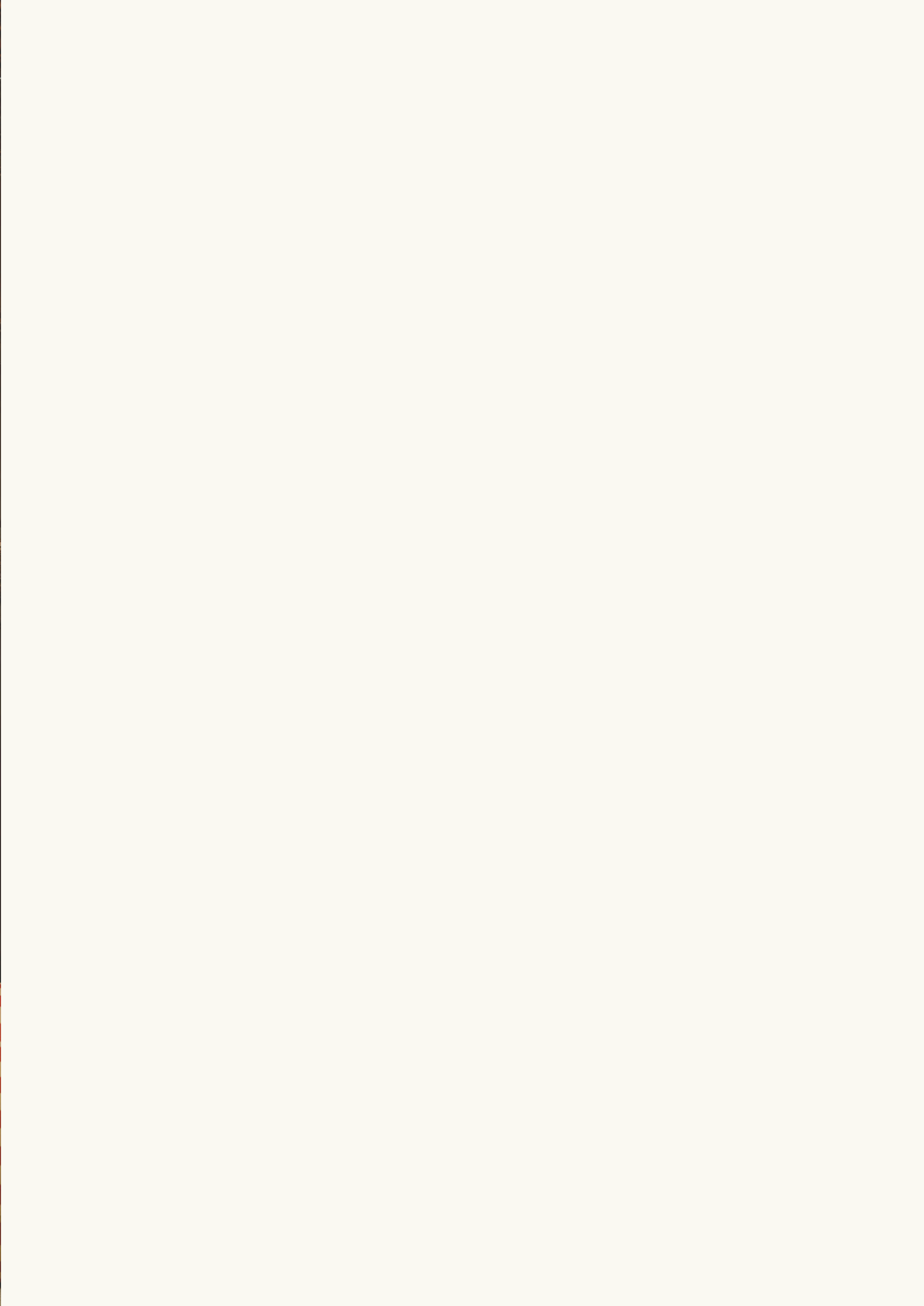

# Carpet

In an exhilarating exchange with the renowned textile designer Nadine Goepfert, we derived this carpet design from the floor plans of the project Sankt Göres - a reinvention of the typology of a duplex house. With the organic layout, this carpet conveys the calm and soothing atmosphere of the Sankt Göres project with its proportionally refined round arched windows contrasting the classic beige brick facade. We managed to enlist cc tapis, the acclaimed Italian carpet rug maker from Milan for a production cooperation. Every carpet is handknotted with 89.000 knots per square metre in Nepal only using Himalayan wool and silk.

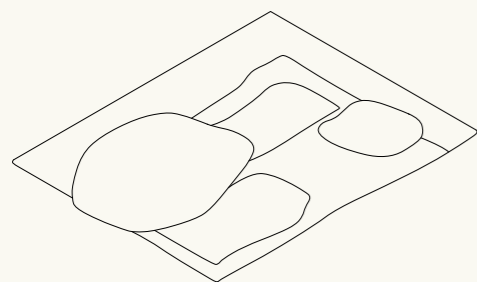

Dimensions: ca. 200 x 250 cm

Design: Nidus x Nadine Goepfert, 2022

Production: Nidus x cc tapis

Handcrafted in Nepal

Material: Himalayan wool & silk

Other: 89.000 knots / sqm

Project: Sankt Göres





# Sofa

The project Kreuzberghof is characterised by the contrasts between linear, clear and almost graphical architectural details versus an overwhelmingly abundance of soft finishes and lavish, organic plantation. It is exactly the combination of the strict and the libertine which inspired this sofa design. A strong structured base is mirrored by the soft and ever changing form of the inviting cushioning on the inside resulting in a sofa design for all facets of life, formal or relaxed. Just like the Kreuzberghof, this sofa is made from materials that get even more beautiful over time; oiled oak on the outside and a washable bouclé fabric for the cushioning.

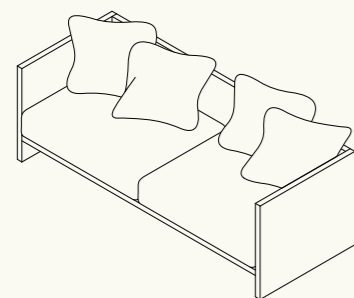

Dimensions: ca. 85 x 210 x 70 cm

Design: Nidus, 2023

Handcrafted in Düsseldorf, Germany

Cushioning: Bouclé by JAB Anstoetz

Frame: Oiled oak

Project: Kreuzberghof



# Armchair

Just like the Nidus sofa, the armchair design is derived from the project Kreuzberghof. In contrast to the sofa, the armchair has a vaguely more formal look to it for it does not have the flexible cushioning but instead a bespoke back cushion which can be supplemented by an additional small pillow making it the perfect armchair for flexible use. Here too, we only used natural materials that get even more beautiful over time. All cushioning is removable and washable.

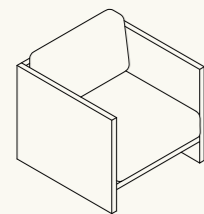

Dimensions: ca. 85 x 85 x 70 cm

Design: Nidus, 2023

Handcrafted in Düsseldorf, Germany

Cushioning: Bouclé by JAB Anstoetz

Frame: Oiled oak

Project: Kreuzberghof

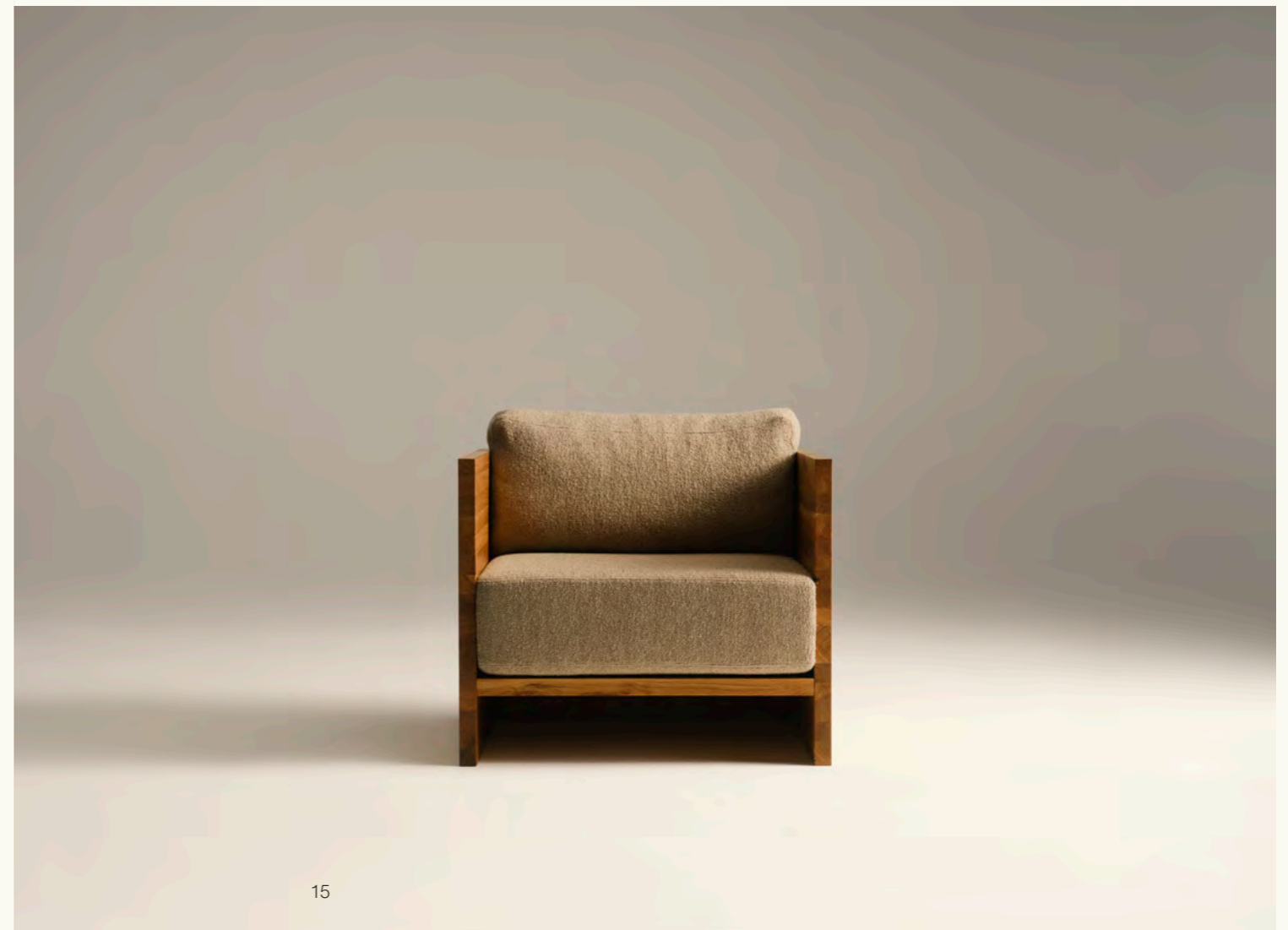





# Table Lamp

Our project Fittings Factory is an abandoned factory from the 1950's which we revived and turned into an office space. Most of the industrial roughness of the building was preserved and combined with warm materials such as oak wood and linen to give the place a good balance between cool and soft. The same goes for our table lamp; the drill cores, taken from the newly embedded staircase, in their typical cylindrical form were used as the lamp stands and are counterparted with soft linen lamp shades in a strictly linear form.

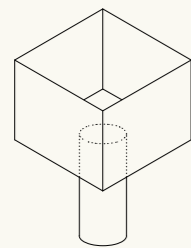
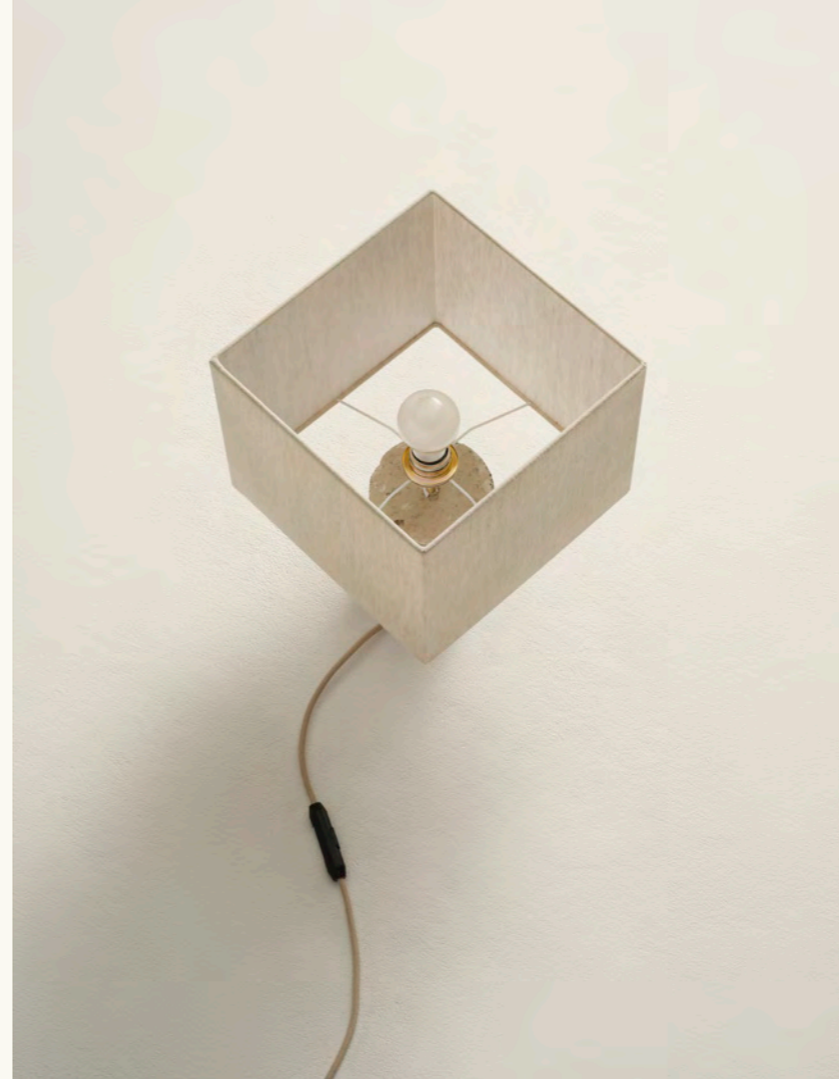

Dimensions: Unique piece, 28 x 28 x 38 cm

Design: Nidus, 2023

Handcrafted in Düsseldorf, Germany

Lamp shade: 100% natural linen, undyed

Base frame: Drill core, concrete

Project: Fittings Factory





# Wall Console

With our Brick House in East Friesland we found a true hidden gem. This petite and thus far, plain, a little neglected farmer's house turned out to be an absolute treasure chest. It is precisely its unpretentious and straight forward design and petiteness that makes this cosy house feel out of this world and special. What could have matched this project better than a true little treasure chest? A small console to bear all your most valued possessions. Be it as a console to greet you in the entrance hall or a night stand to hold you dearest belongings. This versatile chest is so small but it may hold the world inside.

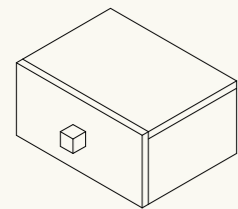

Dimensions: 40 x 20 x 30 cm

Design: Nidus, 2023

Handcrafted in Düsseldorf, Germany

Material: Oiled oak

Project: Brick House





# Quilt

With the project Kreuzberghof we took sustainability to the next level. The rear building is entirely made of wood and completely cycle-orientated in construction. The work on this project has deepened our dedication to the topic of reuse and recycle as well as building structures that can overcome time. This Quilt is a reflection of our explorations in this project. Each quilt is made of waste fabrics from our own projects and therefore a unique piece. The pattern of the quilt is derived from the floor plans of the Kreuzberghof, adaptable and suited for all stages of life. Just like the project itself, this plaid shall be a companion for all kinds of situations and life phases, be it an extravagant bedspread, a cosy blanket or an elaborate tapestry for your wall.

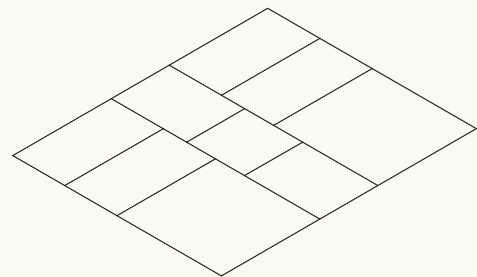

Dimensions: ca. 220 x 180 cm

Design: Nidus, 2023

Handcrafted in Düsseldorf, Germany

Material: Re-used waste fabrics, mostly natural fibres

Project: Kreuzberghof

# Quilt

With the project Kreuzberghof we took sustainability to the next level. The rear building is entirely made of wood and completely cycle-orientated in construction. The work on this project has deepened our dedication to the topic of reuse and recycle as well as building structures that can overcome time. This Quilt is a reflection of our explorations in this project. Each quilt is made of waste fabrics from our own projects and therefore a unique piece. The pattern of the quilt is derived from the floor plans of the Kreuzberghof, adaptable and suited for all stages of life. Just like the project itself, this plaid shall be a companion for all kinds of situations and life phases, be it an extravagant bedspread, a cosy blanket or an elaborate tapestry for your wall.

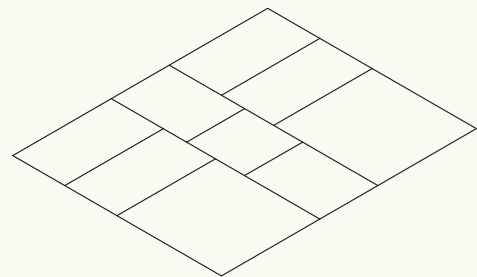

---

Dimensions: ca. 220 x 180 cm

---

Design: Nidus, 2023

---

Handcrafted in Düsseldorf, Germany

---

Material: Re-used waste fabrics, mostly natural fibres

---

Project: Kreuzberghof

---





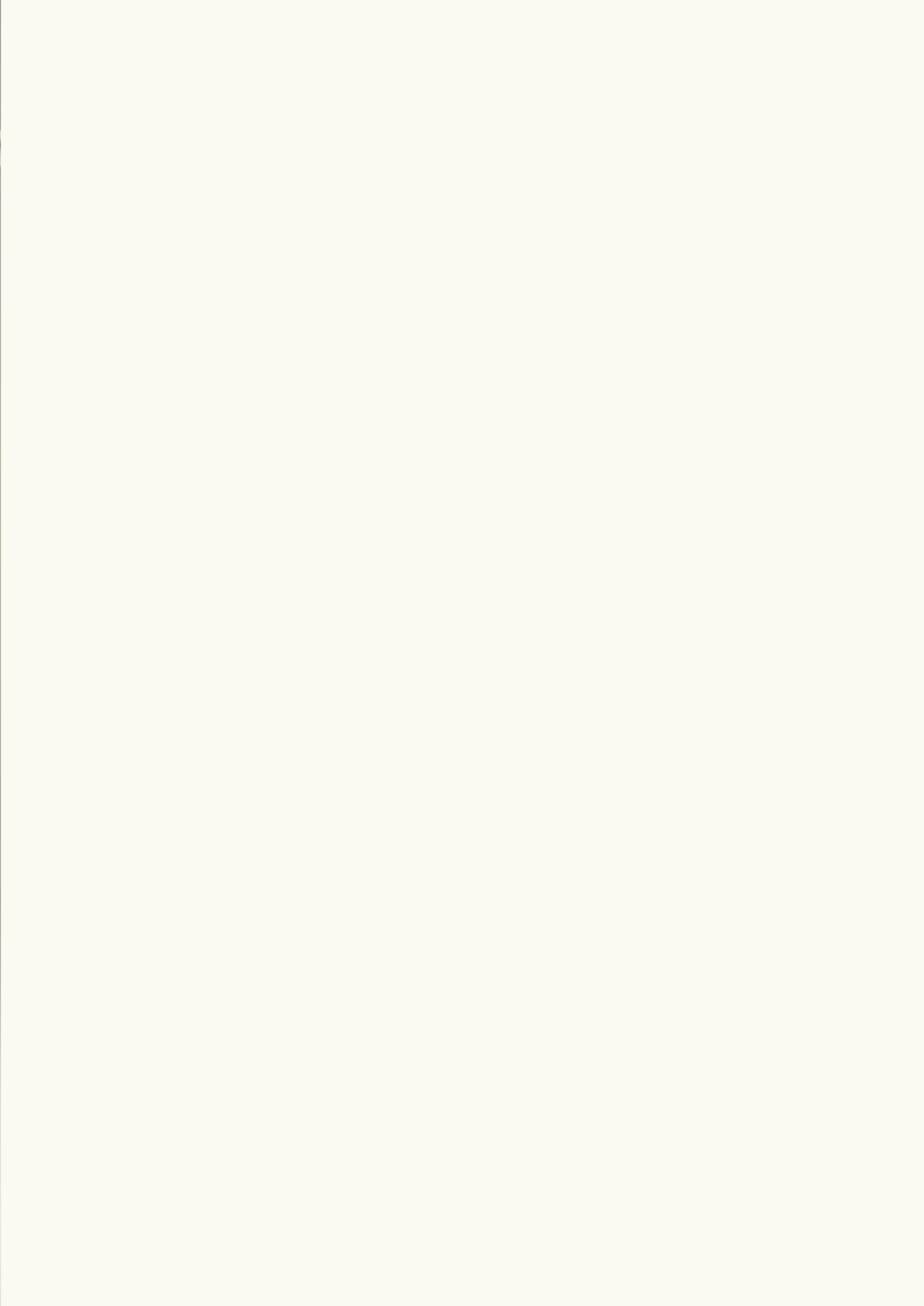

# Pen

No matter how digital your everyday, nothing feels as good as a great pen. Once you find your perfect fit, you never let go of it. It accompanies you in your purse or waits for you to pick it up at work, sometimes it seems if only you have the right pen, the ideas just come sputtering out of your hand. For us, the process of designing architecture is not only a virtual process but also a very physical one, where in workshops we sketch out different ideas and get to know the building we create. No need to say, this requires the best tools available which is why this pen is not linked to just one single project but to the whole Nidus Office instead.

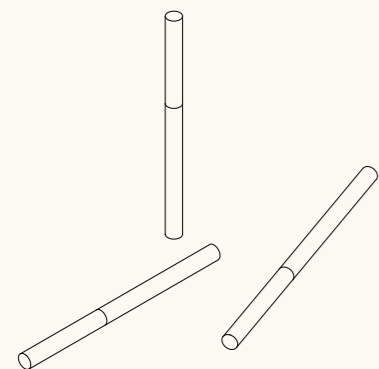

Dimensions: ca. 01 x 15 cm

Design: Nidus, 2022

Handcrafted in Düsseldorf, Germany

Material: Oak, recycled woods: Ebony, Wenge

Project: Nidus Office



Nidus

Judith Schalansky  
**Der Hals  
der Giraffe**  
*Bildungsroman*



# Console

For every felicitous salon one needs two things to start with: first: a great conversational sofa. And secondly, an unintrusive, well designed back table to rest your glass on while you enjoy a good chat or get immersed in a riveting novel. Well, here we go. Matching our sofa collection this console is the perfect addition to the party. However, it not being vain, this is not the only place this console cuts a good figure for it also gives a dashing performance as a rack in you entrance hall.

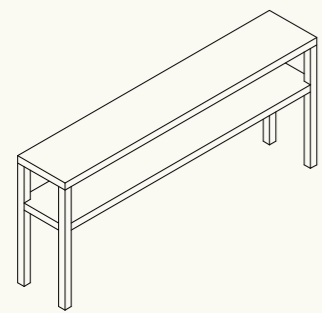

Dimensions: ca. 70 x 160 x 30 cm

Design: Nidus, 2023

Handcrafted in Düsseldorf, Germany

Material: Oiled Oak

Project: Carlstadt Palais



# Table

This sofa table saved from an old glass painting studio is the perfect conclusion to the collection. Formerly used in a glass mosaic workshop, these tables hold stories of the past and have been witness to the most beautiful glass painting creations that are now integrated in architectures all over the world. Rumor has it, even the Vatican's glass mosaics were designed here on these tables. What could better conclude our collection than such emotionally enriched items that show how beautiful an aged piece of furniture can look, how its use can change over the years, how it can convey the passages of time and help create a grounding atmosphere in any setting. Needless to say, these tables are unique pieces, each one telling a different story, bringing something else to the table.

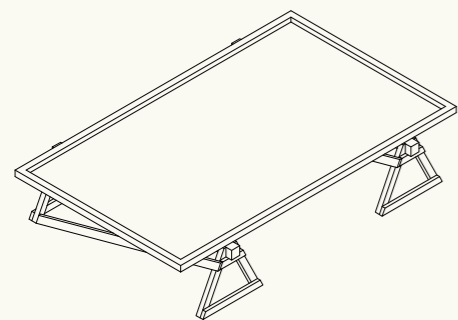

Dimensions: Unique piece, ca. 55 x 207 x 106 cm

Design: unknown, around the 1950s

Handcrafted in Düsseldorf, Germany

Material: different wood types, with signs of use

Project: Mosaic Workshop



# Overview

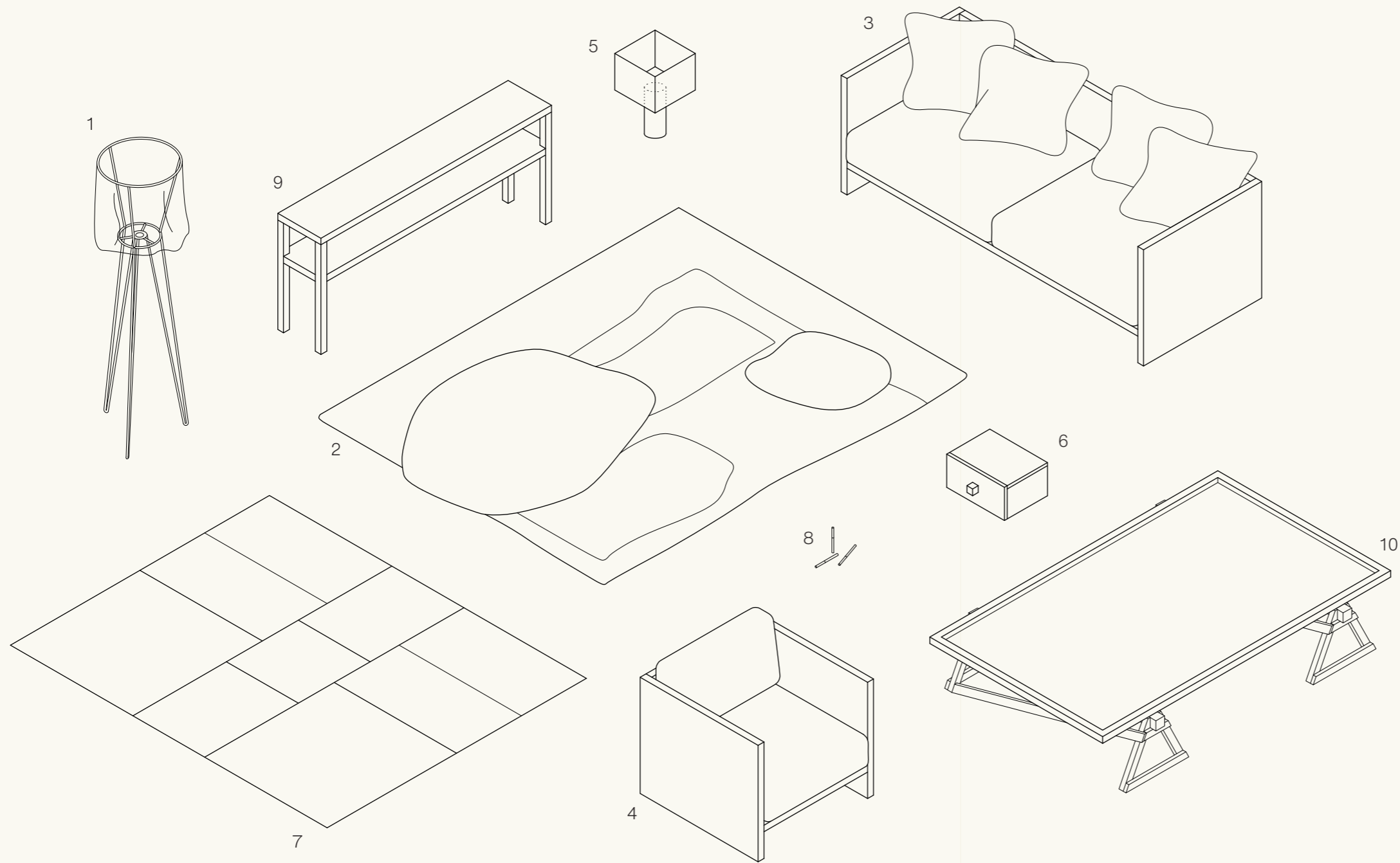

1	Floor Lamp	House Bruno Lambert
2	Carpet	Sankt Göres
3	Sofa	Kreuzberghof
4	Armchair	Kreuzberghof
5	Table Lamp	Fittings Factory
6	Wall Console	Brickhouse
7	Quilt	Kreuzberghof
8	Pen	Nidus Office
9	Console	Carlstadt Palais
10	Table	Mosaic Workshop



Nidus defines architecture and objects for contemporary living and creates experiences that last.



1



2



5

Nidus builds houses for contemporary living, creates interior objects that become more beautiful over time and initiates projects for a broader understanding of building culture.

Contemporary living is not a condition, it is a process. As a matter of fact, our buildings must be designed in such a way that they can respond to this process. This is what drives Nidus: to observe, explore and experiment to build the best possible houses for our societies.

Focusing on the transformation of existing buildings, the portfolio includes projects from the 1890s through the 1950s and 1970s up to today. Each house is unique and tells its own story of context, building history, cohabitation and building techniques. Nidus' interior objects arise from the architectural projects. Designed as travel companions, each piece carries on the story of a building, filling other spaces with the life and soul of a physical place.

Inspired by life and the everyday, Nidus has developed a subtle yet iconic architectural language. A new simplicity, clear structures and high-quality materials create atmospheres of uncompromising quality.

3



4

- 1 Kreuzberghof, Düsseldorf, completion 2024
- 2 Refurbishment of two townhouses in Düsseldorf, completion 2022
- 3 model Kreuzberghof, Düsseldorf, completion 2024
- 4 staircase at House Bruno Lambert, completion 2020
- 5 Townhouse Sankt Göres, Düsseldorf, completion 2023
- 6 exhibition "Das Haus im Buch", 2023
- 7 Sofa from the Nidus Objects Collection, 2023

6

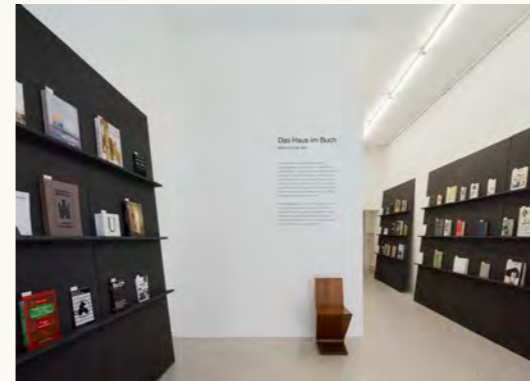

7

8



The most beautiful part of architecture is that it surrounds us everywhere, but even more than that: it provides the stage for life in all its facets. *Building Culture* means going beyond: with a curated program of exhibitions, lectures and concerts taking place in the *Otto Church*, from 2024 on, Nidus opens its doors for encounters and experience of the wide spectrum of architecture.

The owner-managed company was founded in 2016 and is 100 per cent owned by the founders Ana Vollenbroich and Annelen Schmidt-Vollenbroich. The lawyer and the architect met while studying real estate in Frankfurt and immediately shared a passion for architecture.



9

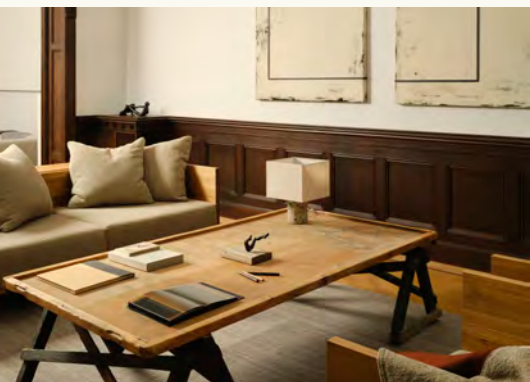

10

52



11



12

13



14

- 8 building structure of the old fitting factory, before renovation
- 9 exhibition opening at the Nidus Architecture Gallery, Düsseldorf
- 10 Nidus Objects on set, 2023
- 11 The founders Annelen Schmidt-Vollenbroich and Ana Vollenbroich
- 12 a new project: the Otto Church from the 1970s, completion 2024
- 13 Warfthouse, Sylt, completion 2021
- 14 Sylt landscape in the evening hours

# Imprint

Nidus GmbH  
Ringelsweide 28  
40223 Düsseldorf

Managing Partners  
Ana Vollenbroich  
Annelen Schmidt-Vollenbroich

District Court Düsseldorf  
HRB 79463

Text  
Nidus

Photography  
Volker Conradus  
Annika Feuss  
Ben Hammer  
Marie Kreibich